





PROJECT		REF		REV	ITEM CODE	
LOCATION		DATE			LEGEND	

SANITARY WARE SPECIFICATION SHEET

<p>Item Descriptions</p> <p>Size</p> <p>Model</p> <p>Finish</p> <p>Material</p> <p>Manufacturer</p> <p>Source</p> <p>Contact Tel/Fax</p> <p>E-mail</p> <p>Website</p>	<p>Pegler (UK) "TX402" Thermostatic mixing valve 15mm; complied with TVM2 & TMV3</p> <p>15 (DN15)</p> <p>5A1560</p> <p>Chrome Plated</p> <p>DZR Brass</p> <p>Pegler Yorkshire (UK)</p> <p>Acme Sanitary Ware Co. Ltd Mr. Eric Wong/ Mr. Don Yuen</p> <p>(852) 2388-7171 / (852) 2710-8012</p> <p>acme@acmesanitary.com.hk</p> <p>www.acmesanitary.com.hk</p>	<p>Illustration/ Drawing</p> <div style="display: flex; justify-content: space-around;">   </div> <div style="display: flex; justify-content: space-around;">   </div>
---	--	---

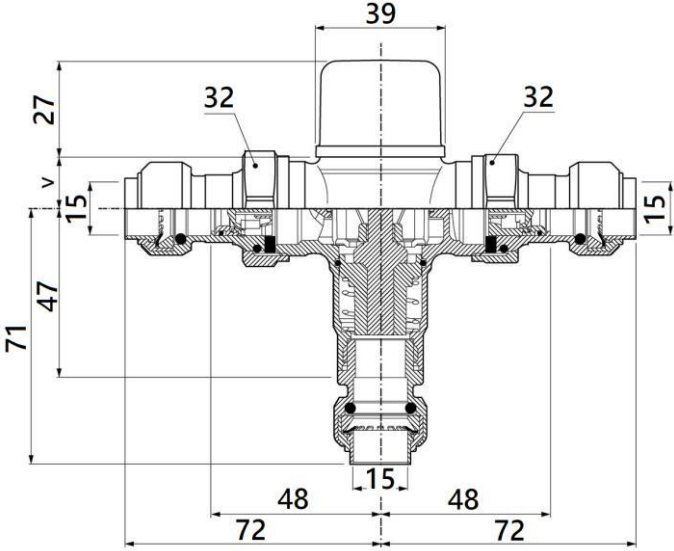
	<p>5A1560 / type TX402</p> <p>The TX402 is an anti-scald thermostatic mixing valve complete with Tectite push fit connections which combines high quality manufacturing and top of the range performance with ease of installation and servicing. Pegler anti-scald TMV's are the ideal choice for eliminating the risk of scalding in healthcare, public and educational buildings, commercial and domestic projects and are WRAS approved.</p> <ul style="list-style-type: none"> • Simplicity of installation and servicing • Temperature pre-set to 43°C, but easily adjustable on site • Simple to install and service • 15mm sizes.
---	--

Note:

** All information of the above is for the reference only. No prior notice is made if any changes.*

GENERAL SPECIFICATION - TX402 RANGE TMV3/2 THERMOSTATIC MIXING VALVES

TX402	
Materials	DZR Brass
Surface finish	Chrome plate
Water connections 15mm and 22mm	Tectite fittings all ends. Water strainers. Single non return valves on inlets

TUBE COMPATABILITY	
Tube connections	Copper, Chrome Copper, PEX with Liners (6 bar @65°C, 3 bar @ 95°C max pressure) Stainless steel

TECHNICAL SPECIFICATION - TMV3

WHEN USED AS TMV3 VALVE		
	General operating parameters	TMV3 approved parameters
Minimum mixed temperature	30°C	38°C
Maximum mixed temperature	50°C	46°C
Maximum temperature deviation	+/- 2°C	+/- 2°C
Maximum hot inlet temperature	85°C	65°C
Maximum hot/cold, cold/hot inlet pressure ratio	5 to 1	N/A
Maximum static pressure	12 bar	10 bar
Minimum dynamic flow pressure	0.1 bar	0.2 bar
Minimum hot inlet to mixed outlet temperature differential	10°C	10°C
Flow with 0.2 bar differential pressure loss	9.0L/M	9.0L/M
Flow 1.0 bar differential pressure loss	18L/M	18L/M

APPROVALS - TMV3

WHEN USED AS TMV3 ARE APPROVED BY WRAS FOR THE FOLLOWING USES:				
Code	Operating range	Size	Application	Max. temperature
HP-B	High pressure	15mm, 22mm	Bidet	38°C
HP-S	High pressure	15mm, 22mm	Shower	41°C
HP-W	High pressure	15mm, 22mm	Washbasin	41°C
HP-T44	High pressure	15mm, 22mm	Bath	44°C
HP-T46	High pressure	15mm, 22mm	Bath	46°C (assisted)
LP-B	Low pressure	15mm, 22mm	Bidet	38°C
LP-S	Low pressure	15mm, 22mm	Shower	41°C
LP-W	Low pressure	15mm, 22mm	Washbasin	41°C

INSTALLATION CONDITIONS - TMV3

TO COMPLY WITH THE BUILD CERT TMV3 SCHEME THE VALVES MUST BE INSTALLED UNDER THE FOLLOWING CONDITIONS:		
Operating pressure range	Low pressure	High pressure
Maximum static pressure (bar)	10	10
Flow pressure, hot and cold (bar)	0.2-1	1-5
Hot supply temperature (°C)	52-65	52-65
Cold supply temperature (°C)	5-20	5-20

TECHNICAL SPECIFICATION - TMV2

TECTITE TX402 TMV WHEN USED AS TMV2 VALVE		
	BS EN 1287:1999	BS EN 1111:1999
Maximum static pressure	10.0	10.0
Supply pressure hot and cold	0.1-1.0	0.5-5.0
Hot supply (°C)	55-65	55-65
Cold supply (°C)	Maximum 25	Maximum 25
Mixed water temperature (°C)	Maximum 46	Maximum 46

APPROVALS - TMV2

TECTITE TX402 TMV WHEN USED AS TMV2 VALVE				
Code	BS EN 1287:1999 low pressure 0.1 - 1 bar		BS EN 1111:1999 high pressure 1.5 bar	
	15mm	22mm	15mm	22mm
Bidet	-	✓	✓	✓
Shower	-	✓	✓	✓
Washbasin	-	✓	✓	✓
Tub	-	-	✓	✓
Bath fill (Cold isolation at 46°C)	-	-	✓	✓

INSTALLATION CONDITIONS - TMV2

TO COMPLY WITH THE BUILDCERT TMV2 SCHEME THE VALVES MUST BE INSTALLED UNDER THE FOLLOWING CONDITIONS:		
Operating pressure range	Low pressure	High pressure
Maximum static pressure (bar)	10	10
Flow pressure, hot and cold (bar)	0.1-1	0.5-5.0
Hot supply temperature (°C)	55-65	55-65
Cold supply temperature (°C)	≤ 25	≤ 25

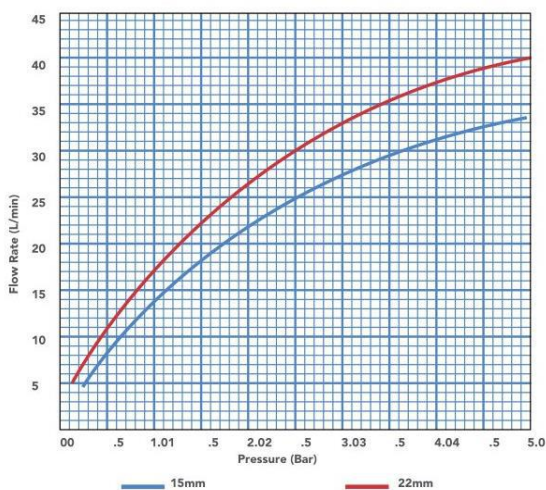

TECTITE TX402 TMV3/2 FLOW PRESSURE GRAPH

These products are certified under the Buildcert TMV scheme having been independently tested by an approved testing laboratory WRc-NSF, and are a Water Regulations Advisory Scheme (WRAS) approved product and is listed in the Water Fittings and Materials Directory.

Installation, adjustment, in service testing and maintenance is covered in the installation operating and maintenance instructions supplied with each Tectite TMV.



水務署
Water Supplies Department

總部 Headquarters

香港灣仔告士打道七號入境事務大樓 48 樓

48/F, Immigration Tower, 7 Gloucester Road, Wan Chai, Hong Kong

本署檔號
Our ref.
來函檔號
Your ref.



/19 T/J(1193/2019)

電話
Tel.
傳真
Fax.

: 2824 0578

22 January 2020



Dear Madam,

**Approval of “PEGLER” Thermostatic Blending Valves
(General Acceptance No. B20200007)**

Your letter ref. Q-0355/19 dated 23 December 2019 refers.

It is noted that the fittings described below have been accepted by the United Kingdom Water Regulations Advisory Scheme (WRAS) to have complied with the requirements of the United Kingdom Water Supply (Water Fitting) Regulations / Scottish Water Byelaws when correctly installed. This Authority accepts that the fittings described below based on the WRAS certificate and test reports ref. BC-SUMMARY-2019-35 and BC-SUMMARY-2019-37 both issued on 19 December 2019 by Castco Testing Centre Limited comply with, and their use when correctly installed does not contravene, the Waterworks Ordinance and Regulations.

Name of Manufacturer: Pegler Yorkshire Group Limited

Country of Origin: UK

Brand: Pegler

Details of Fittings: Range of concealed ‘T’ type thermostatic blending valves (chromium plated DZR brass bodies). The inlets incorporate a stainless steel strainer and single check valve cartridge. Maximum working pressure 10.0 bar. Maximum operating temperature 60°C.



Model and Size: PEG402 – 15mm and 22mm
TX402 – 15mm and 22mm

Body Markings: Model, Pegler & on cap. Tectite & ‘P’ on body

WRAS Approval Number: 1907010

Installation Requirements: R001, R010, R040

Expiry Date: 31 July 2024

In view of the acceptance by WRAS, this Authority has no objection to the use of the said fittings in fresh water plumbing systems subject to full adherence to Waterworks installation requirements. In particular, you are required to draw your customers' attention to the following installation requirements –

“Installation shall comply with the ‘Installation Requirements & Notes’ of the WRAS’s approval letter concerned.” AND

“The cold water supply to the fittings shall be drawn from the same source that supplies the hot water apparatus so as to provide a balanced pressure and to obviate the risk of scalding in the event of a restriction or failure in the water supply.”

A condition of this acceptance is that the fittings to be installed should be replicas of the samples certified by WRAS and no modification should be made to the fittings. This acceptance may be withdrawn at any time if the standard of the fittings installed fails to meet that of the approved samples or if the fittings are found to be unsuitable for use in fresh water plumbing systems.

This acceptance is only applicable to the main body of the fittings, unless otherwise specified.

For the use of the fittings in any project, the General Acceptance Number of this letter must be quoted as a means of identification of acceptance of the fittings by this Authority.

Should you have any enquiries, please contact our Engineer Mr. Terry KUNG at tel. no. 3583 4086.

Yours faithfully,



(CHAN Chung-kun)

for Director of Water Supplies

Encl.

c.c. WSD 3321/1/82] - without catalogue
ME/MC] - with soft copy only

NSF International

Recognises that

AALBERTS INTEGRATED PIPING SYSTEMS UK

Has had the following products certified as complying with:
BS EN 1111:2017 Thermostatic Mixing Valves (High Pressure) ⁽¹⁾⁽²⁾, BS EN 1287:2017
Thermostatic Mixing Valves (Low Pressure) and all applicable requirements.

Range of concealed T-type Thermostatic Mixing valves:
PEG402, PEG402UA & PEG402UAX – 15mm & 22mm Compression
TX402, TX402UA & TX402UAX – 15mm & 22mm Push Fit

Products appearing in the NSF official listing for the TMV2 Scheme are authorised to bear the NSF Mark below.



Simon Warburton

Simon Warburton, Certification Manager, Water.

Certificate: NSF2410/0821
Issue Date: 26th Aug 2021
Expiry Date: 26th Aug 2026



0110

(1) Excluding: Clause 14 Acoustic Characteristics
(2) Excluding: 6.1 Marking (Acoustic & Flowrate Class)

This certificate is the property of NSF International and must be returned upon request. This certificate remains valid as long as this client has products in the listing for the referenced standard. For the most current and complete listing information, please access NSF's website (www.nsf.org).

NSF Wales Limited (Trading as NSF International)
Unit 30 Fern Close, Pen-Y-Fan Industrial Estate, Oakdale, Gwent, NP11 3EH
Tel: +44 (0) 1495 236 260

NSF International

Recognises that

Pegler Yorkshire Group Ltd

Has had the following products certified as complying with:
The Department of Health (DH) Health Technical Memorandum 04-01: Supplement
Performance specification D 08; thermostatic mixing valves (healthcare premises) and all applicable requirements.

Range of concealed T-type Thermostatic Mixing Valves
PEG402, PEG402UA & PEG402UAX - 15mm & 22mm Compression
TX402, TX402UA & TX402UAX - 15mm & 22mm Push Fit

Products appearing in the NSF official listing for the TMV3 Scheme are authorised to bear the NSF Mark below.



Paul Taylor
Certification Director

Certificate: NSF2140/0819
Issue Date: 29th August 2019
Expiry Date: 15th August 2024



This certificate is the property of NSF International and must be returned upon request. This certificate remains valid as long as this client has products in the listing for the referenced standard. For the most current and complete listing information, please access NSF's website (www.nsf.org).

NSF Wales Limited (Trading as NSF International)
Unit 30 Fern Close, Pen-Y-Fan Industrial Estate, Oakdale, Gwent, NP11 3EH
Tel +44(0) 1495 236 260

Pegler

Domestic Valve Solutions



Installation Instructions and User Guide

15mm & 22mm
In-Line Thermostatic Mixing Valve

PEG402, PEG402UA & PEG402UAX
TMV3 / TMV2 Combined

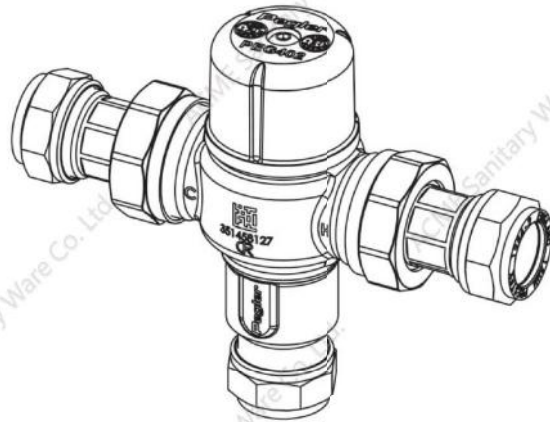

It is important that these guidance notes are read and fully understood prior to product installation



PEG402

When used as a TMV3 (TYPE3) valve:

IMPORTANT INTRODUCTION NOTES

The valves covered by these instructions have been tested and certified as being in compliance with BS 7942:2000 and NHS Estates Model Engineering Specification D 08.

Valves operating outside the requirements of these standards are not covered by the TMV3 Scheme and are not guaranteed to operate as Type 3 valves.

The installer should be aware of his duty of care and responsibility in ensuring that compliance with regulations is maintained. The valve is not guaranteed to function correctly to the TMV3 specification unless it is installed and used in accordance with these instructions. Regular servicing is essential to ensure continued safe operation of this thermostatic mixing valve. The recommended service interval must be based on the valve response to the in-service cold water failure test results.

This Pegler Model PEG402 in-line thermostatic mixing valve, available in 15mm and 22mm sizes, is intended to be fitted into applications where the reliable control of hot water temperature is necessary to prevent scalding. In the event of cold water supply failure, the product will shut off the hot water supply.

Water regulations

The Pegler Model PEG402 mixing valve must be installed in accordance with the regulations of the local water company and the Water Supply (Water Fittings) Regulations 1999.

Approvals

This product is certified under the TMV3 scheme and has been independently tested by the recognised test laboratory WRC-NSF and is a Water Regulations Advisory Scheme (WRAS) approved product and listed in the Water Fittings and Materials Directory.

Installation

Separate isolation valves must be installed on the hot and cold water inlet supplies. To ensure proper performance of the thermostatic mixing valve, the isolating valves should preferably be full bore and always be fully open during operation.

The mixing valve is supplied with filter elements but it is advisable to additionally install Y-strainers on the hot and cold water supplies. The isolating valves and strainers should be installed as close as practicable to the location of the mixing valve and should always be in an accessible location.

Before installation, the hot and cold water supply systems must be thoroughly flushed to remove any dirt/debris that may have accumulated. Failure to do so may adversely affect the performance of the mixing valve.

CONDITIONS OF NORMAL USE

Table 1

Operating Range	High Pressure	Low Pressure
Maximum static pressure - bar	10	10
Hot & cold flow pressure - bar	1.0 to 5	0.2 to 1
Hot supply temperature - °C	55 to 65	55 to 65
Cold supply temperature - °C	5 to 20	5 to 20

Minimum hot inlet to mixed outlet temperature differential =10°C

Note: Valves operating outside these conditions can not be guaranteed by the Scheme to operate as Type 3 valves.

The highest flow rates will be achieved under balanced pressure conditions, but the pressure at the valve inlets must be within a ratio of 5:1 under flow conditions and the size and layout of pipework and fittings must take this into account.

FITTING

Before installation, the system operating conditions of inlet pressures, hot water temperature and hot and cold water flow rates should be determined and confirmed to be within the expected conditions of normal use.

Valves must operate in either a high pressure setting or a low pressure setting valves are not capable of operation with, for instance hot water supply in one pressure range and cold water supply in the other pressure range. In these conditions it is necessary to either boost one pressure or reduce the other so that both supplies are within a common pressure range.

Correct location of the mixing valve is important to ensure that it is accessible for commissioning and servicing.

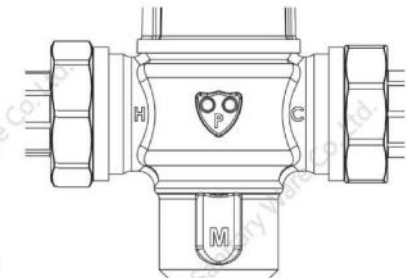

- The valve body is clearly marked with 'C' for Cold and a blue indicator and 'H' for Hot and a red indicator. The valve must be correctly connected to the respective supplies.

- The use of sealing compounds must be avoided since they may intrude into the water supply and impair the valve performance.

The Pegler Model PEG402 thermostatic mixing valve is supplied with the tail pieces, inlet filter screen and main body gasket seals separately located in the packing box. Each tail piece comprises: a housing with union nut and an internally fitted, WRAS approved non-return valve.

Assembly Procedure

- Unpack the main valve assembly and check that the bores are free of debris and the end sealing faces are clean.
- Unpack the two tailpieces and confirm they are complete with union nuts and compression nuts and olives.
- Locate the sealing gaskets, insert them into the union nuts against the faces of the tailpieces and screw the union nuts onto the valve until a tight seal has been made.
- Remove the compression nuts and olives from the tailpieces. Locate the inlet filter screens and insert them into the bore of the tailpieces up to the shoulder.
- Assemble the valve to the pipework and ensure the hot and cold water pipes have full penetration into the tailpiece.
- Tighten the compression nuts ensuring that the end of the pipe remains in contact with the filter element.

Exploded view of tail pipe assembly

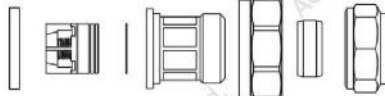

The Pegler Model PEG402UA mixing valve is optionally provided with angled assemblies in lieu of the tailpiece arrangement shown above. This allows the connections of the hot and cold water supplies to be parallel to the mixed water outlet for ease of piping layouts. The angled valve assemblies incorporate non-return valves, filters, isolation valves and test points.

The assemblies comprise an integral full bore ball valve and in-line strainer in an angled housing. When this arrangement is used, the requirements for isolation valves and Y-strainers previously mentioned are regarded as fulfilled.

The PEG402UAX version includes a modified outlet allowing a 'cold water' connection to outlets.

Exploded view of UA angle valve assembly

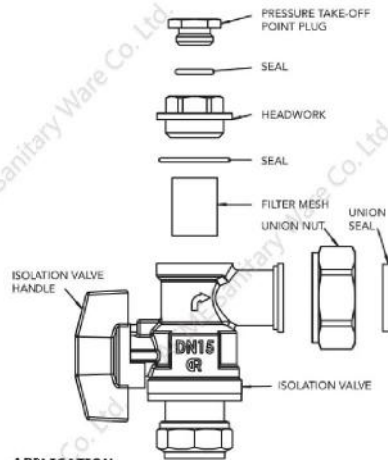

APPLICATION

The Pegler Model PEG402 thermostatic mixing valve has been independently tested by WRC-NSF against the requirements of BS 7942:2000 and NHS D08 and certified as complying with the requirements of the TMV3 Scheme and is suitable for use in the designations shown in the table below.

Valves approved for designation for use 'HP' only:- If a water supply is fed by gravity then the supply pressure should be verified to ensure the conditions of use are appropriate for the valve.

Table 2 – Required maximum set outlet temperatures at commissioning (TMV 3 Only).

Application	Designation	Maximum Set Mixed Water Temperature
Bidet	HP-B LP-BE	38°C
Shower	HP-S LP-SE	41°C
Washbasin	HP-W LP-WE	41°C
Bath*	HP-T44	44°C
Bath* (assisted)	HP-T46	46°C

*22mm only

The range of available temperature adjustment is 35°C to 48°C **BUT** the mixed water temperature at the terminal fitting should never be set to a temperature that exceeds the maximum set outlet temperature for the application (Table 2).

Note:

46°C is the maximum recommended mixed water temperature from the bath tap. The maximum temperature takes account of the allowable temperature tolerances inherent in thermostatic mixing valves and temperature losses in metal baths.

46°C is not a safe bathing temperature for adults or children.

The British Burns Association recommends 37°C to 37.5°C as a comfortable bathing temperature for children. In premises covered by the Care Standards Act 2000, the maximum mixed water outlet temperature is 43°C.

COMMISSIONING (TMV 3)

The valve must be commissioned under normal site system conditions and after establishing supply conditions with the hot and cold water supplies open, leave the system running to allow temperatures and pressures to stabilise and be checked.

Prior to commencing commissioning, the following checks should be carried out.

- The designation of the thermostatic mixing valve matches the application.
- The supply pressures and temperatures are within the operating range of the valve.
- Isolating valves and strainers are provided.
- The supply temperatures are within the range permitted for the valve and by guidance information on the prevention of legionella etc.

If all these conditions are met, proceed to set the temperature as described below. The Pegler Yorkshire model PEG402 thermostatic mixing valve is supplied factory set at 43°C but the valve may be simply adjusted after installation.

The mixed water temperature at the terminal fitting must never exceed the maximum temperature setting for the particular application (See Table 2). Note, It is not possible to install one thermostatic mixing valve to supply two differing applications unless the temperature of the higher setting is limited to that of the lower application.

- Remove the plastic protective cap on top of the valve with the supplied Allen key or other suitable tool.

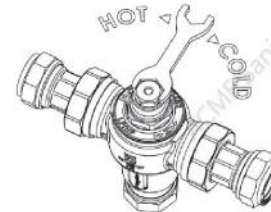

- using a close fitting spanner, reduce the mixed outlet temperature by turning clockwise.
- increase the mixed water outlet temperature by turning counter clockwise.

When the valve has been installed with the correct conditions of use it is advised that the valve is subjected to exercise prior to the commissioning at the application temperature. With hot and cold water flowing through the valve, operate the valve from full cold to full hot at least three times.

With the valve at the full cold position bring the valve to the correct application temperature by turning the spanner counter clockwise. If the valve overshoots this temperature, return the valve to the full cold condition, and reset it to the correct temperature +0-2°C. Do not set a valve on a lowered temperature as this will not provide consistent operation.

When the valve is set to the required temperature for the application carry out 5 cold water isolation tests to further exercise the valve.

Commissioning Test sequence

After adjust the temperature of the mixed water in accordance with the valve application (see Table 2) and the carry out the following sequence:

- Record the temperature of the hot and cold water supplies.
- Record the temperature of the mixed water at the largest draw-off flow rate.
- Record the temperature of the mixed water flow at a smaller draw-off flow rate, which shall be measured.
- Isolate the cold water supply to the mixing valve and monitor the mixed water temperature recording the maximum temperature achieved and the final stabilised temperature.
- Record the equipment, thermometer etc. used for the measurements.

Note: The final stabilised temperature should not exceed the values in Table 3.

Table 3 - Guide to maximum stabilised temperatures recorded during commissioning

Application	Mixed water temperature °C
Bidet	40
Shower	43
Washbasin	43
Bath (44°C fill)	46
Bath (46°C fill)	48



After correct commissioning secure the protective cap using the supplied screw.

In Service Testing (TMV 3)

The purpose of in-service testing is to regularly monitor and record the performance of the thermostatic mixing valve. Deterioration in performance can indicate the need for service work on the valve and/or water supplies.

Carry out the test sequence detailed below using the same or equivalent equipment as used for commissioning the valve.

- Check the designation of the thermostatic valve matches the application.
- Check that the supply pressures and temperatures are within the operating range of the valve.
- Check that the supply temperatures are within the range permitted for the valve and by guidance information on the prevention of legionella etc.
- Check there have been no significant changes in inlet supply temperatures and pressures since commissioning or the previous in service test.
If significant changes have occurred it is recommended to re-commission the valve.

If the mixed water temperature has changed significantly from the previous test results (e.g. >1°C), record the change and before re-adjusting the mixed water temperature carry out the following checks;

- All in-line or integral strainers are clean
- Any in-line or integral non-return valves or other anti-backsiphonage devices are in good working order.
- Any isolation valves are fully open.

With an acceptable mixed water temperature complete the Commissioning test sequence detailed above. If the final mixed water temperature is greater than the values in Table 3 and/or the maximum temperature exceeds the corresponding value from the previous test results by more than about 2°C the need for service work is indicated (see TMV servicing and cleaning instructions).

In-service tests should be carried out with a frequency which identifies a need for service work before an unsafe water temperature can result.

Frequency of in-service testing

6 to 8 weeks after commissioning carry out the test sequence detailed above.

12 to 15 weeks after commissioning carry out the test sequence detailed above.

Depending on the results obtained, the following course of actions must be followed:

- If no significant changes (e.g. <1 °C) in mixed water temperature are recorded between commissioning and testing at 6 to 8 weeks, or between commissioning and testing at 12 to 15 weeks, the next in-service test can be deferred to 24 to 28 weeks after commissioning.
 - If small changes (e.g. 1 to 2 °C) in mixed water temperature are recorded in only one of these periods, necessitating adjustment of the mixed water temperature, then the next in-service test can be deferred to 24 to 28 weeks after commissioning.
 - If small changes (e.g. 1 to 2 °C) in mixed water temperature are recorded in both of these periods, necessitating adjustment of the mixed water temperature, then the next in-service test should be carried out at 18 to 21 weeks after commissioning.
 - If significant changes (e.g. >2 °C) in mixed water temperature are recorded in both of these periods, necessitating service work, then the next in-service test should be carried out at 18 to 21 weeks after commissioning.
- The general principle to be observed after the first 2 or 3 in-service test is that the intervals of future tests should be set to those which previous tests have shown can be achieved with no more than a small change in mixed water temperature. It is recommended that In-Service Tests are carried out once every 6 months as a minimum.

Note:

If there is a residual flow during the commissioning or in service test during the cold water supply isolation test then this is acceptable providing the temperature of the water seeping from the valve is no more than 2°C above the designated maximum mixed water outlet temperature setting of the valve as defined in Table 2.

Temperature readings should be taken at the normal flow rate after allowing the system to stabilise. The sensing part of the thermometer probe must be fully submerged in the water that is to be tested.

Any TMV that has been adjusted or serviced must be re-commissioned and re-tested in accordance with the manufacturer's instructions.

PEG402 When used as a TMV2 (TYPE 2) Valve

IMPORTANT INTRODUCTION NOTES

The valves covered by these instructions have been tested and certified as being in compliance with BS EN 1111:1999 and BS EN 1287:1999.

Valves operating outside the requirements of these standards are not covered by the TMV2 Scheme and are not guaranteed to operate as Type 2 valves.

The installer should be aware of his duty of care and responsibility in ensuring that compliance with regulations is maintained. The valve is not guaranteed to function correctly to the TMV2 specification unless it is installed and used in accordance with these instructions. Regular servicing is essential to ensure continued safe operation of this thermostatic mixing valve. The recommended service interval is no greater than 12 months.

This Pegler Model PEG402 in-line thermostatic mixing valve, available in 15mm and 22mm sizes, is intended to be fitted into applications where the reliable control of hot water temperature is necessary to prevent scalding. In the event of cold water supply failure, the product will shut off the hot water supply.

Water regulations

The Pegler Model PEG402 mixing valve must be installed in accordance with the regulations of the local water company and the Water Supply (Water Fittings) Regulations 1999.

Approvals

This product is certified under the TMV2 scheme and has been independently tested by an approved testing laboratory WRC-NSF and is a Water Regulations Advisory Scheme (WRAS) approved product and listed in the Water Fittings and Materials Directory.

Installation

Separate isolation valves must be installed on the hot and cold water inlet supplies. To ensure proper performance of the thermostatic mixing valve, the isolating valves should preferably be full bore and always be fully open during operation. The mixing valve is supplied with filter elements but it is advisable to additionally install Y-strainers on the hot and cold water supplies.

The isolating valves and strainers should be installed as close as practicable to the location of the mixing valve and should always be in an accessible location.

Before installation, the hot and cold water supply systems must be thoroughly flushed to remove any dirt/debris that may have accumulated. Failure to do so may adversely affect the performance of the mixing valve.

CONDITIONS OF NORMAL USE

Table 4

Operating Range	BS EN 1111 High Pressure	BS EN 1287 Low Pressure
Maximum static pressure - bar	10	10
Hot & cold flow pressure - bar	0.5 to 5	0.1 to 1
Hot supply temperature - °C	55 to 65	55 to 65
Cold supply temperature - °C	± 25	± 25
Mixed water temperature - °C	Maximum 46	Maximum 46

Minimum hot inlet to mixed outlet temperature differential = 10°C

Note: Valves operating outside these conditions can not be guaranteed by the Scheme to operate as Type 2 valves.

The highest flow rates will be achieved under balanced pressure conditions, but the pressure at the valve inlets must be within a ratio of 5:1 under flow conditions and the size and layout of pipework and fittings must take this into account.

FITTING

Before installation, the system operating conditions of inlet pressures, hot and cold inlet temperature and hot and cold water flow rates should be determined and confirmed to be within the expected conditions of normal use shown in Table 4.

Valves must operate in either a high pressure setting or a low pressure setting. These valves are not capable of operation with, for instance hot water supply in one pressure range and cold water supply in the other pressure range. In these conditions it is necessary to either boost one pressure or reduce the other so that both supplies are within a common pressure range.

If your water supply cannot meet these conditions then the valve cannot be guaranteed to operate as a Type 2 valve.

Operating pressures above 5.0 Bar will require the installation of a pressure reducing valve. Correct location of the mixing valve is important to ensure that it is accessible for commissioning and servicing.

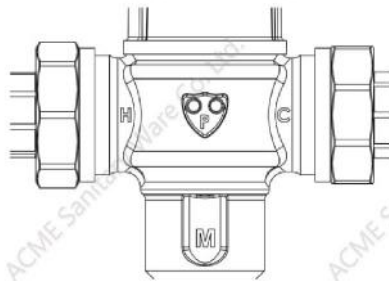

Exploded view of tailpiece assembly

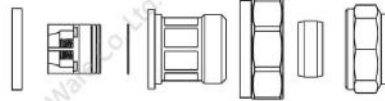

The Pegler Model PEG402UA mixing valve is optionally provided with angled assemblies in lieu of the tailpiece arrangement shown above. This allows the connections of the hot and cold water supplies to be parallel to the mixed water outlet for ease of piping layouts. The assemblies comprise an integral full bore ball valve and in-line strainer in an angled housing. When this arrangement is used, the requirements for isolation valves and strainers previously mentioned are regarded as fulfilled.

Exploded view of UA angle valve assembly

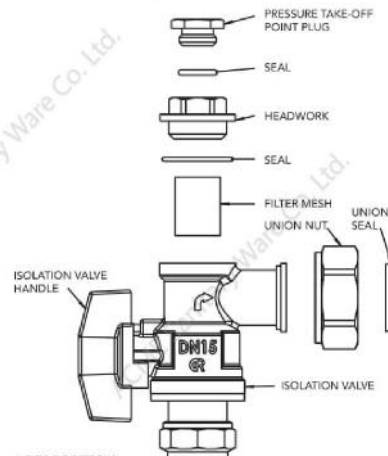

APPLICATION

The Pegler Model PEG402 thermostatic mixing valve has been independently tested by WRC-NSF against the requirements of BS EN 1287 (Low Pressure-LP) and BS EN 1111 (High Pressure-HP) and certified as complying with the requirements of the TMV2 Scheme and is suitable for use in the designations shown in the table (next page).

Valves approved for designation for use 'HP' only-

If a water supply is fed by gravity then the supply pressure should be verified to ensure the conditions of use are appropriate for the valve.

- The valve body is clearly marked with 'C' for Cold and a blue indicator and 'H' for Hot and a red indicator. The valve must be correctly connected to the respective supplies.
- The use of sealing compounds must be avoided since they may intrude into the water supply and impair the valve performance.
- The valve must be so installed that it is readily accessible for commissioning and maintenance when being installed in accordance with TMV2.
- The valve must be installed with isolation valves on both the hot and cold water systems as close as possible to the valve; so as to allow the valve to be commissioned and tested correctly.
- The valve is supplied with integral strainers on the hot and cold water supplies therefore in-line strainers should not be required.
- The valve is fitted with integral "listed" non-return valve cartridges which command the water supply, therefore the thermostatic valve is protected against cross-flow due to unbalanced line pressures as required by the Water Supply (Water Fittings) Regulations 1999.

Assembly Procedure

- Unpack the main valve assembly and check that the bores are free of debris and the end sealing faces are clean.
- Unpack the two tailpieces and confirm they are complete with union nuts and compression nuts and olives.
- Locate the sealing gaskets, insert them into the union nuts against the faces of the tailpieces and screw the union nuts onto the valve until a tight seal has been made.
- Remove the compression nuts and olives from the tailpieces. Locate the inlet filter screens and insert them into the bore of the tailpieces up to the shoulder.
- Assemble the valve to the pipework and ensure the hot and cold water pipes have full penetration into the tailpiece.
- Tighten the compression nuts ensuring that the end of the pipe remains in contact with the filter element.

7

Table 5 – Recommended set mixed water outlet temperatures

Application	Pressure		Maximum set mixed water temperature
	15mm	22mm	
Shower	HP	HP and LP	41°C
Wash basin	HP	HP and LP	41°C
Sidet	HP	HP and LP	38°C
Bath (Tub)	HP	HP	44°C

The above temperatures are recommended by the Thermostatic Mixing Valve (manufacturers) Association as relevant settings for the varying applications shown. This is the maximum commissioning temperature but valves may exceed this by 2°C in use.

The range of available temperature adjustment is 35°C to 48°C but 46°C is the maximum recommended mixed water temperature from a bath tap. The maximum temperature takes account of the allowable temperature tolerances inherent in thermostatic mixing valves and temperature losses in metal baths.

46°C is not a safe bathing temperature for adults or children.

The British Burns Association recommends 37°C to 37.5°C as a comfortable bathing temperature for children. In premises covered by the Care Standards Act 2000, the maximum mixed water outlet temperature is 43°C.

COMMISSIONING (TMV 2)

The valve must be commissioned under normal site system conditions and after establishing supply conditions with the hot and cold water supplies open, leave the system running to allow temperatures and pressures to stabilise and be checked.

Prior to commencing commissioning, the following checks should be carried out.

- The designation of the thermostatic mixing valve matches the application.
- The supply pressures and temperatures are within the operating range of the valve.
- Isolating valves and strainers are provided. If all these conditions are met, proceed to set the temperature as described below.

The Pegler PEG402 thermostatic mixing valve is supplied factory set at 43°C but the valve may be simply adjusted after installation.

The set mixed water temperature at the terminal fitting must never exceed 46°C

- Remove the plastic protective cap on top of the valve with the supplied Allen key or other suitable tool.
- using a close fitting spanner, reduce the mixed outlet temperature by turning clockwise.
- increase the mixed water outlet temperature by turning counter clockwise.

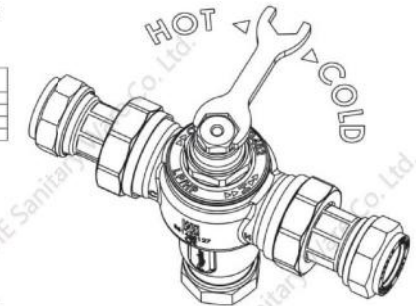

When the valve has been installed with the correct conditions of use it is advised that the valve is subjected to exercise prior to the commissioning at the application temperature. With hot and cold water flowing through the valve, operate the valve from full cold to full hot at least three times.

With the valve at the full cold position bring the valve to the correct application temperature by turning the spanner counter clockwise. If the valve overshoots this temperature, return the valve to the full cold condition, and reset it to the correct temperature +0-2°C. Do not set a valve on a lowered temperature as this will not provide consistent operation.

When the valve is set to the required temperature for the application carry out 5 cold water isolation tests to further exercise the valve.

- Set the mixed water temperature to the required value. It is advisable to use a calibrated digital thermometer for checking the inlet and outlet temperatures.
- Measure and record the temperature of the hot and cold water supplies at the inlets to the valve.
- Measure and record the temperature of the water discharging from the valve at the greatest draw-off flow rate.
- In the absence of other temperatures being specified those detailed in Table 5 are the desired settings.

Once the required mixed outlet temperature has been achieved, isolate the cold water supply and monitor and record the mixed water temperature including the maximum and final temperatures achieved. **The mixed water temperature should never exceed 46°C.**

8

After correct commissioning secure the protective cap using the supplied screw.

Record all the equipment used during commissioning.

In Service testing (TMV 2)

The Pegler Model PEG402 thermostatic mixing valve will provide satisfactory service and a high level of protection, provided it is maintained and subjected to **In-Service Testing**.

Approximately 6-8 weeks after commissioning, the following tests should be undertaken.

- Check the temperature of the hot and cold water supplies - **RECORD**
- Check the temperature of the mixed water temperature at the greatest draw off flow rate - **RECORD**
- Check there have been no significant changes in inlet supply temperatures and pressures since commissioning or the previous in service test. If significant changes have occurred it is recommended to re-commission the valve.

If the mixed water temperature has significantly changed from that measured at installation (e.g. > 1°C), **RECORD** the change and before making any adjustments to the valve confirm that:-

- Strainer elements in the hot and cold water supplies are clean and undamaged.
- Non-return valves are clean and operating correctly.
- Isolation valves are operating correctly and are set in the fully open position.

If the mixed water temperature is acceptable, the following additional observations should be made:-

Isolate the cold water supply and **RECORD** the maximum temperature achieved. After 5 seconds, if water is still flowing **RECORD** the temperature of the flow. Restore the cold water supply and **RECORD** the stabilised mixed water outlet temperature.

- If there is no significant change to the stabilised set outlet temperature ($\pm 2^\circ\text{C}$ or less deviation from the original setting) and the fail safe shut-off is functioning, then the valve is working correctly and no further service work is required.
- If the maximum mixed water temperature exceeds the previous test results by more than 2°C then the need for service work on the valve is indicated.
- The equipment used in these In-Service Tests should be **RECORDED** and should preferably be the same as that used at installation.

Note:

If there is a residual flow during the commissioning or the annual verification (cold water supply isolation test) then this is acceptable providing the temperature of the water seeping from the valve is no more than 2°C above the designated maximum mixed water outlet temperature setting of the valve (See Table 5).

Temperature readings should be taken at the normal flow rate after allowing the system to stabilise. The sensing part of the thermometer probe must be fully submerged in the water that is to be tested. Any TMV that has been adjusted or serviced must be re-commissioned and re-tested in accordance with the manufacturer's instructions.

In the absence of any other instruction or guidance, it is recommended that In-Service Tests are carried out once every 12 months as a minimum. If the temperature is outside of the expected range it will be necessary to remove and clean the valve in accordance with the following instructions.

TMV Cleaning and Servicing Instructions (TMV 2 & TMV 3)

Most domestic water supplies contain calcium which will separate out when the water is heated in a system. The degree and speed of scaling may vary depending on factors such as water flow rates, system design, the hardness of the water and the temperature to which the water is heated. Deposits of scale may over time form in the valve, particularly at the hot inlet. The formation of the scale may adversely affect the performance of the valve which will be detected during the in-service testing. If this occurs it will be necessary to remove the valve for de-scaling and servicing.

N.B.

Excessive chemical dosing may result in internal damage to valve components and remove lubrication leading to valve failure.

- Isolate the hot and cold supply.
- Remove the valve to a clean working area.
- Remove the protective cap.
- Unscrew the headwork of the valve.
- Carefully remove the element and valve assembly and put to one side.
- Remove the main spring and flow guide and carefully put to one side.
- Inspect the components for contamination or damage.
- Clean or replace as necessary.
- Remove the two o rings.
- Clean the valve body and headwork using a proprietary de-scaler.
- Thoroughly rinse the body and headwork in clean water.
- Carefully fit new o rings from the service kit taking care to ensure they are not damaged and are correctly located.
- Lubricate the o rings with the lubricant provided.
- Re-fit the flow guide and spring lubricating the flow guide around the greatest diameter with the lubricant provided.
- Lubricate the shuttle valve with the lubricant provided.
- Re-fit the shuttle valve and element assembly.
- Re-fit the headwork ensuring correct tightening.
- Re-fit the valve assembly.
- If after cleaning the valve, and replacing the o ring seals, the valve does not function correctly, it may be necessary to replace the thermal element.

Spares

In order to ensure that the Model PEG402 thermostatic mixing valve continues to provide satisfactory service, only GENUINE Pegler spare parts must be used.

Exploded view of TMV assembly

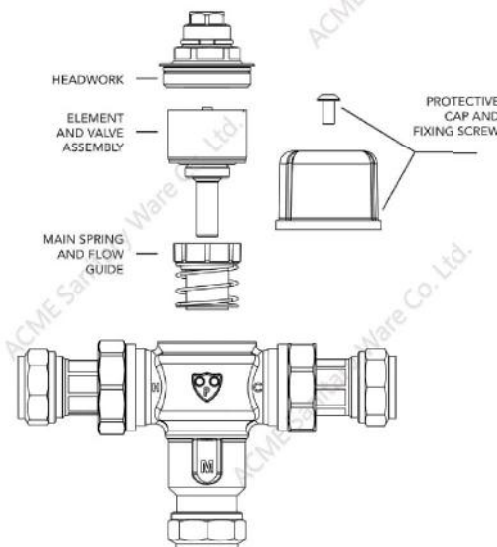

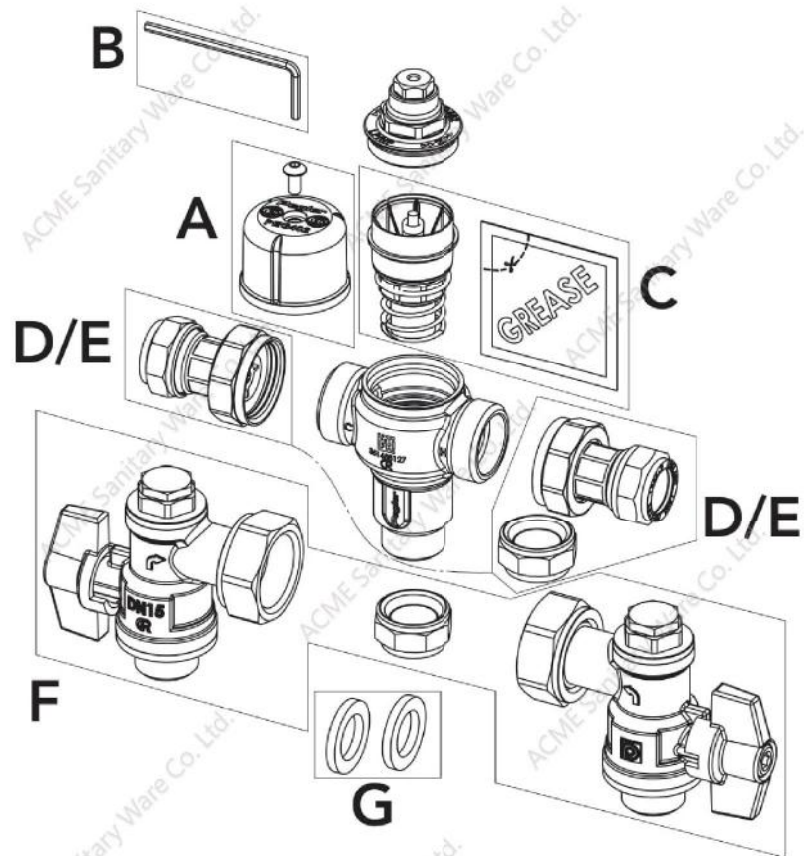

	Spare part order code	Description
A	854863	Blue Protective cap complete with screw
B	854447	Hexagon key
C	854454	Service kit
D	854865 (15mm), 854866 (22mm)	Tailpipe assembly
E	854867 (15mm), 854868 (22mm)	Ext. Tailpipe assembly
F	854451 (15mm), 854452 (22mm)	Angle valve strainer kit
G	854456 (15mm), 854457 (22mm)	Sealing washer